

Алматы (7273)495-231  
Ангарск (3955)60-70-56  
Архангельск (8182)63-90-72  
Астрахань (8512)99-46-04  
Барнаул (3852)73-04-60  
Белгород (4722)40-23-64  
Благовещенск (4162)22-76-07  
Брянск (4832)59-03-52  
Владивосток (423)249-28-31  
Владикавказ (8672)28-90-48  
Владимир (4922) 49-43-18  
Волгоград (844)278-03-48  
Вологда (8172)26-41-59  
Воронеж (473)204-51-73  
Екатеринбург (343)384-55-89

Ижевск (3412)26-03-58  
Иваново (4932)77-34-06  
Иркутск (395)279-98-46  
Казань (843)206-01-48  
Калининград (4012)72-03-81  
Калуга (4842)92-23-67  
Кемерово (3842)65-04-62  
Киров (8332)68-02-04  
Коломна (4966)23-41-49  
Кострома (4942)77-07-48  
Краснодар (861)203-40-90  
Красноярск (391)204-63-61  
Курск (4712)77-13-04  
Курган (3522)50-90-47  
Липецк (4742)52-20-81

Магнитогорск (3519)55-03-13  
Москва (495)268-04-70  
Мурманск (8152)59-64-93  
Набережные Челны (8552)20-53-41  
Нижний Новгород (831)429-08-12  
Новокузнецк (3843)20-46-81  
Ноябрьск (3496)41-32-12  
Новосибирск (383)227-86-73  
Омск (3812)21-46-40  
Орел (4862)44-53-42  
Оренбург (3532)37-68-04  
Пенза (8412)22-31-16  
Петрозаводск (8142)55-98-37  
Псков (8112)59-10-37  
Пермь (342)205-81-47

Ростов-на-Дону (863)308-18-15  
Рязань (4912)46-61-64  
Самара (846)206-03-16  
Саранск (8342)22-96-24  
Санкт-Петербург (812)309-46-40  
Саратов (845)249-38-78  
Севастополь (8692)22-31-93  
Симферополь (3652)67-13-56  
Смоленск (4812)29-41-54  
Сочи (862)225-72-31  
Ставрополь (8652)20-65-13  
Сыктывкар (8212)25-95-17  
Сургут (3462)77-98-35  
Тамбов (4752)50-40-97  
Тверь (4822)63-31-35

Тольяти (8482)63-91-07  
Томск (3822)98-41-53  
Тула (4872)33-79-87  
Тюмень (3452)66-21-18  
Улан-Удэ (3012)59-97-51  
Ульяновск (8422)24-23-59  
Уфа (347)229-48-12  
Хабаровск (4212)92-98-04  
Чебоксары (8352)28-53-07  
Челябинск (351)202-03-61  
Череповец (8202)49-02-64  
Чита (3022)38-34-83  
Якутск (4112)23-90-97  
Ярославль (4852)69-52-93

Киргизия (996)312-96-26-47

Россия (495)268-04-70

Казахстан (772)734-952-31

<https://huber.nt-rt.ru> || [hru@nt-rt.ru](mailto:hru@nt-rt.ru)

## КАТАЛОГ на автомобильный контроль температуры



Extremely precise  
**temperature control solutions**

for materials testing, quality assurance, environmental simulation  
and much more

# The right solution for every Application



There are numerous applications for Huber temperature control systems in the aerospace, aviation and automobile industries. Typical applications include environmental simulations, material inspection, and temperature-dependent stress and load tests for materials, motors, bearings, fuel and engine parts.

Other common uses include research work, test series and quality controls on batteries, rechargeable batteries, sensors and electronic components. Researchers and engineers all over the world rely on our temperature control technology when constructing and operating test rigs.

## Applications:

Test rig construction  
Material testing  
Quality control  
Stress tests

Environmental simulation  
Battery testing  
Solar technology  
Motor / bearing testing

Calibration  
and much more



## Temperature change tests

Small thermal regulation baths can be used for temperature change tests. Tests and pre-examinations can be carried out on material samples in the bath, quickly and easily. High-performance circulation thermostats are ideal for thermal tests that require a wide temperature range.

Various temperature conditions can be simulated,  $-40\text{ }^{\circ}\text{C}$  to  $85\text{ }^{\circ}\text{C}$  is a common test range but wider ranges are possible to as low as  $-120\text{ }^{\circ}\text{C}$  up to  $425\text{ }^{\circ}\text{C}$ .



## Test rigs

We supply individually designed temperature control equipment in every performance class for temperature tests on engines, drives, drivetrains and other components. Our temperature control solutions are ideal for integration into test rigs and deliver reproducible temperatures.

If a system division into primary and secondary circuits is required due to test rig requirements based on material incompatibilities, pressure, viscosity, flow rates etc, Huber can offer an option for design and delivery of external heat exchanger solutions in loose or built-on format.



## Addition/alternative to environmental chamber

Huber temperature control units are ideal as an alternative or extension to environmental chambers to lower their operational temperature range. Our temperature control units can be used in a wide range of tests, and often cost less than environmental chambers. Yet another benefit is the high temperature control speed which can be achieved with Unistats. Heating and cooling capacity can be trans-

ferred quickly and precisely – a critical advantage in many functional and material tests.

The combination of temperature control unit and environmental chamber allows simultaneous simulation of specimen temperatures as a function of environmental temperatures.

# Temperature control solutions for Test rig construction, aviation



## Battery Test

Functional tests for lithium ion rechargeable batteries in electric vehicles



## Transmission oil test

Continual heating and cooling for durability testing



## Calibration

Calibration tasks in the vehicle sensor area



## Charpy Impact Test

Deformation capacity for components in air conditioning systems



## Fogging Test

Measurement of volatile substances in materials used in vehicle interiors

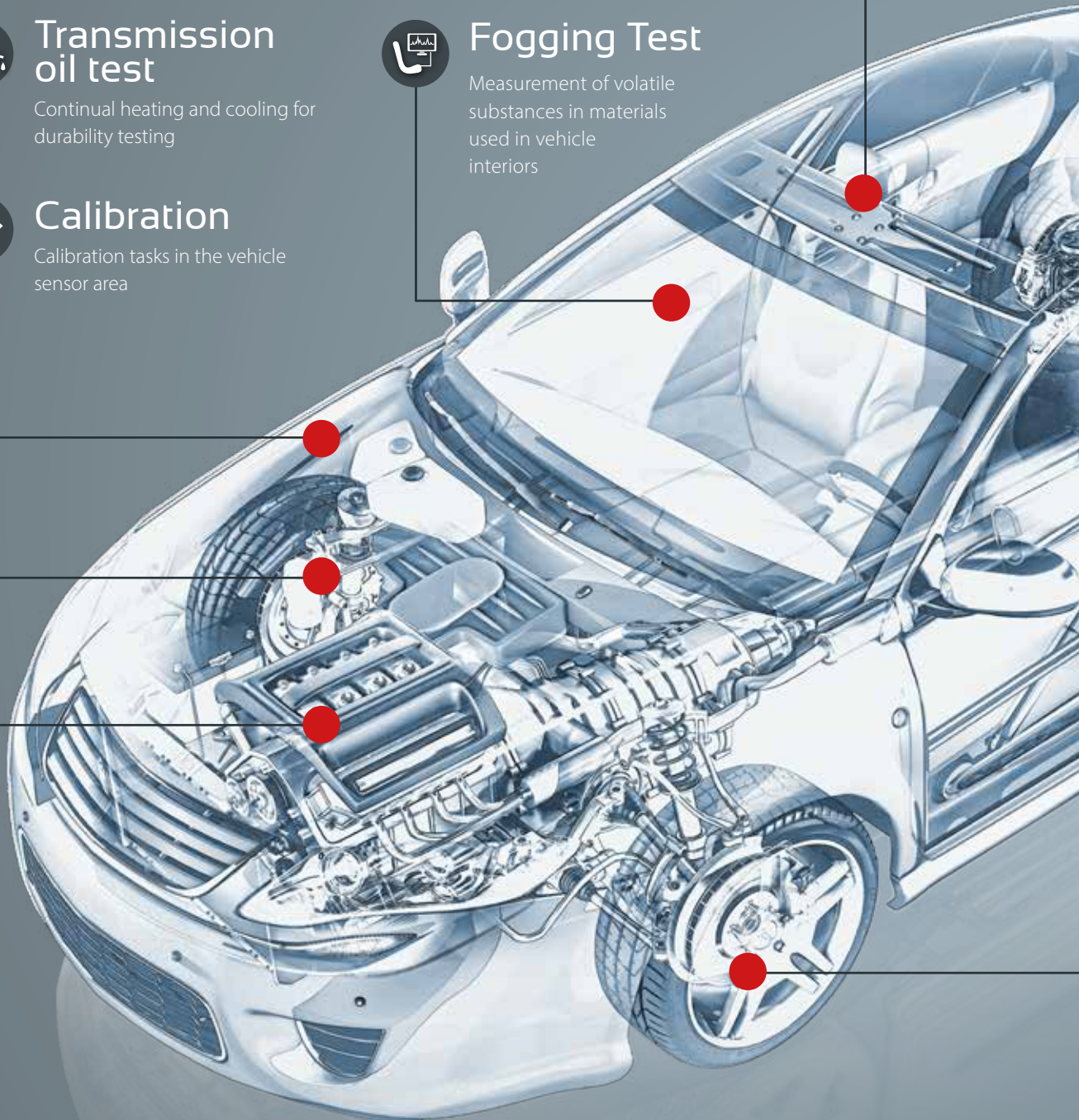

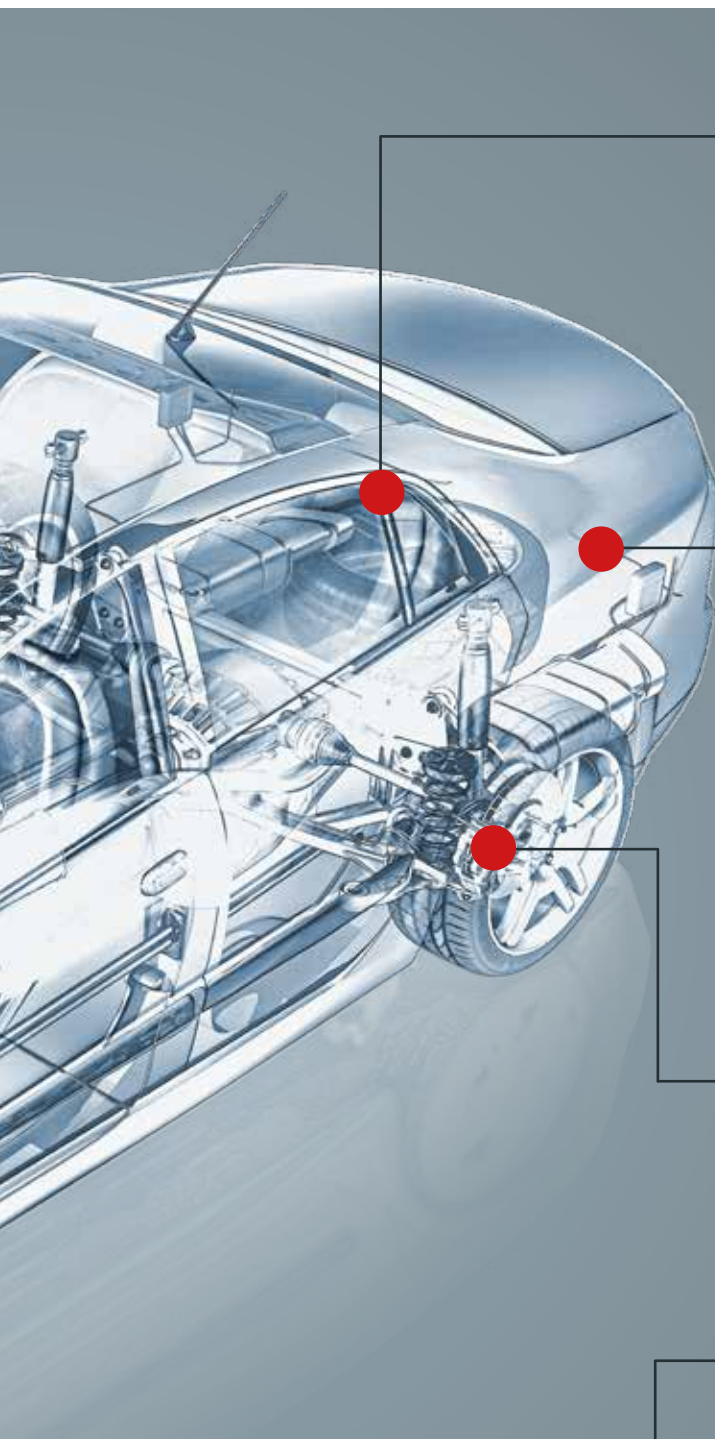

## Vicat test

Tests for softening point for plastics



## Cold filter plugging point

Determination of cold filter plugging point of diesel fuels



## Fuel temperature control

Durability tests for fuel tanks



## AdBlue<sup>®</sup> temperature control

Exhaust post-treatment of diesel fuels in cars



## Stress test in test rigs

Long-term loading of vehicle components over several weeks under conditions of extreme temperatures



## Corrosion testing

Corrosion testing with cyclical temperature fluctuation, moisture and saline vapour

# Highest accuracy

# Unimotive

The Unimotive model series is specially designed for applications in the automotive industry. The temperature control systems are constructed for operation with water-ethylene glycol mixture with corrosion protection (for example Glysantin®) down to -45 °C. Typical applications

include temperature simulations as well as material testing and temperature-dependent stress and load tests for automotive parts and functional components. The optionally available "Flow Control Cube" enables precise flow rate measurement and control.

 **Up to +95 °C**  
Temperature range

 **Up to 35 kW**  
Cooling power

 **Up to 145 l/min**  
Pump capacity

 **Pilot ONE**  
Touch screen controller

 **Direct operation with water-ethylene glycol mixture**

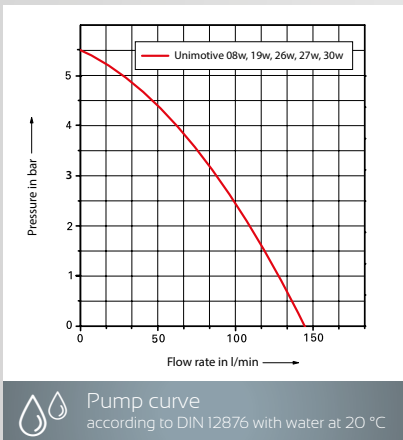

An additional pump curve with water-ethylene glycol mixture can be found on our website.



Model	Temperature range (°C)	Pump max. VPC <sup>1</sup>		Heating power (kW)	Cooling power (kW) at (°C)				Dimensions W x D x H (mm)	Cat.No.
		(l/min)	(bar)		20	0	-20	-40		
Unimotive 08w	-45...95	145	5,5	12,0	14,0	10,0	5,0	0,8	730x860x1520	1089.0001.01
Unimotive 19w	-45...95	145	5,5	12,0	18,0	14,0	8,5	1,9	730x860x1520	1090.0001.01
Unimotive 26w	-45...95	145	5,5	24,0	28,0	25,0	14,5	2,6	730x860x1520	1091.0001.01
Unimotive 27w	-45...95	145	5,5	24,0	35,0	25,0	14,5	2,6	730x860x1520	1094.0001.01
Unimotive 30w	-45...95	145	5,5	12,0	21,0	17,5	9,5	3,0	730x860x1520	1096.0001.01

# Individually configurable Options for your application



## AUTOMATION

Support for common data communication standards and software solutions for data recording, remote operation and programming.

Interfaces: e.g. Profibus, Modbus TCP, Ethernet, OPC-UA, RS232, RS485, USB, Analogue.



## CIRCULATION PUMPS

Various pump options and optional pressure booster pumps allow flexible alignment of pressure and flow volume for the application.



## SENSOR OPTIONS

A selection of Pt100 sensors for temperature measurement and regulation at relevant points.



## DRY CONNECT/ DISCONNECT

Press & Twist connections make it easier to change the application on the temperature control unit. Having a wide internal bore the pressure drop is low keeping flow resistance to a minimum to promote efficient thermal transfer and temperature control.



## WATER GLYCOL

Direct operation with water glycol as a temperature control medium is possible with many Unistats, as well as use of electrically non-conductive liquids (e.g. 3M Novec).



## EXPANSION

A range of expansion vessels is available as accessories for compensation of temperature-dependant volume changes.



## MEASUREMENT AND CONTROL OF HTF

VPC bypasses and various flow rate meters allow measurement and control of heat transfer fluid (HTF) pressure and flow volume.



## CONNECTION SETS

Preconfigured sets consisting of T-bend and pipe extension for connecting additional M-FCC Flow Control Cubes.

# Flow measurement and control

## Flow Control Cube

The Flow Control Cubes are used to measure and control the flow and pressure of the thermal fluid. They can be used with Huber temperature control units with Pilot ONE technology.

Flow measurement is magnetic-inductive (MID models) or via a turbine (TURB models).

- FCC MID is suitable for electrically conductive liquids (e.g. water or water-glycol mixtures).
- FCC TURB is suitable for all Huber fluids (e.g. DW Therm or silicone oils such as M60.115/200.06)
- The turbine can be calibrated for different tempering fluids (e.g. for Huber fluids or also water-glycol mixtures)

	<b>Flow Control Cube MID<sup>1</sup></b> ▶ Flow measurement magnetically-inductive	<b>Flow Control Cube TURB</b> ▶ Flow measurement via turbine
Temperature range	-40 ... 130 °C	-90 ... 250 °C
Permitted fluids	Water or Water/Glycol	Water/Glycol 50/50 <sup>2</sup>
Accuracy flow control <sup>3</sup>	up to ± 0,1 l/min	up to ± 0,2 l/min
Min. volume flow	0,2 l/min	0,9 l/min
Max. volume flow	80 l/min	95 l/min
Max. permitted pressure	6,0 bar	6,0 bar
Dimensions WxDxH	425x600x520 mm	425x600x520 mm
Weight, netto	approx. 49 kg	approx. 50 kg
Noise level	ca. 43 dB (A)	ca. 43 dB (A)
Fluid connection	M30x1,5 AG	M30x1,5 AG
Power supply	90–240V 1~50/60Hz	90–240V 1~50/60Hz
Max. current	0,2 A	0,2 A
Fuse protection	2,0 A	2,0 A
Protection class	IP20	IP20
Min. ambient temperature	5 °C	5 °C
Max. ambient temperature	40 °C	40 °C
Suitable for units	Applications with volume flow of max. 85 l/min	Applications with volume flow of max. 95 l/min <sup>4</sup>
Construction / Design	On castors, loose <sup>5</sup>	On castors, loose <sup>5</sup>
<b>Cat.No.</b>	<b>10925</b>	<b>10937</b>

<sup>1</sup> Due to the technology used, the MID does not have to be explicitly matched to the medium used

<sup>2</sup> Calibration factory set up with 50/50, adjustment to another medium can be done by customer

<sup>3</sup> At 20 °C and water-glycol mixture 50/50. The accuracy is influenced by various factors (in particular the set flow rate, the fluid used, the fluid temperature).

<sup>4</sup> Volume flow >95 l/min on request

<sup>5</sup> Accessories for use with the FCC e.g. hoses, adapters, etc. must be ordered separately

<sup>6</sup> FCC is supplied assembled



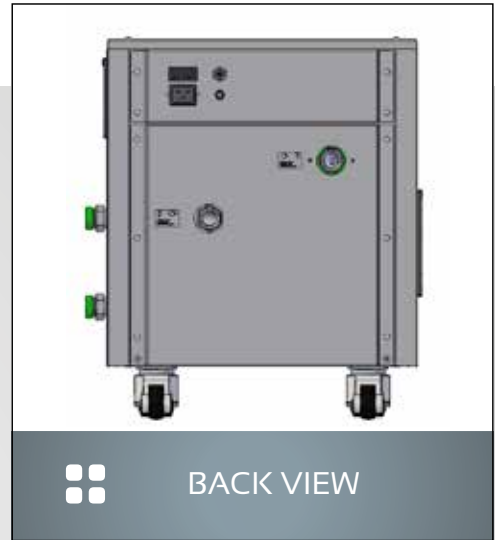

Interface options:  
 RS232/485, USB, Ethernet,  
 Modbus TCP, Profibus, OPC-UA

## SINGLE-CIRCUIT CONTROL WITH FCC

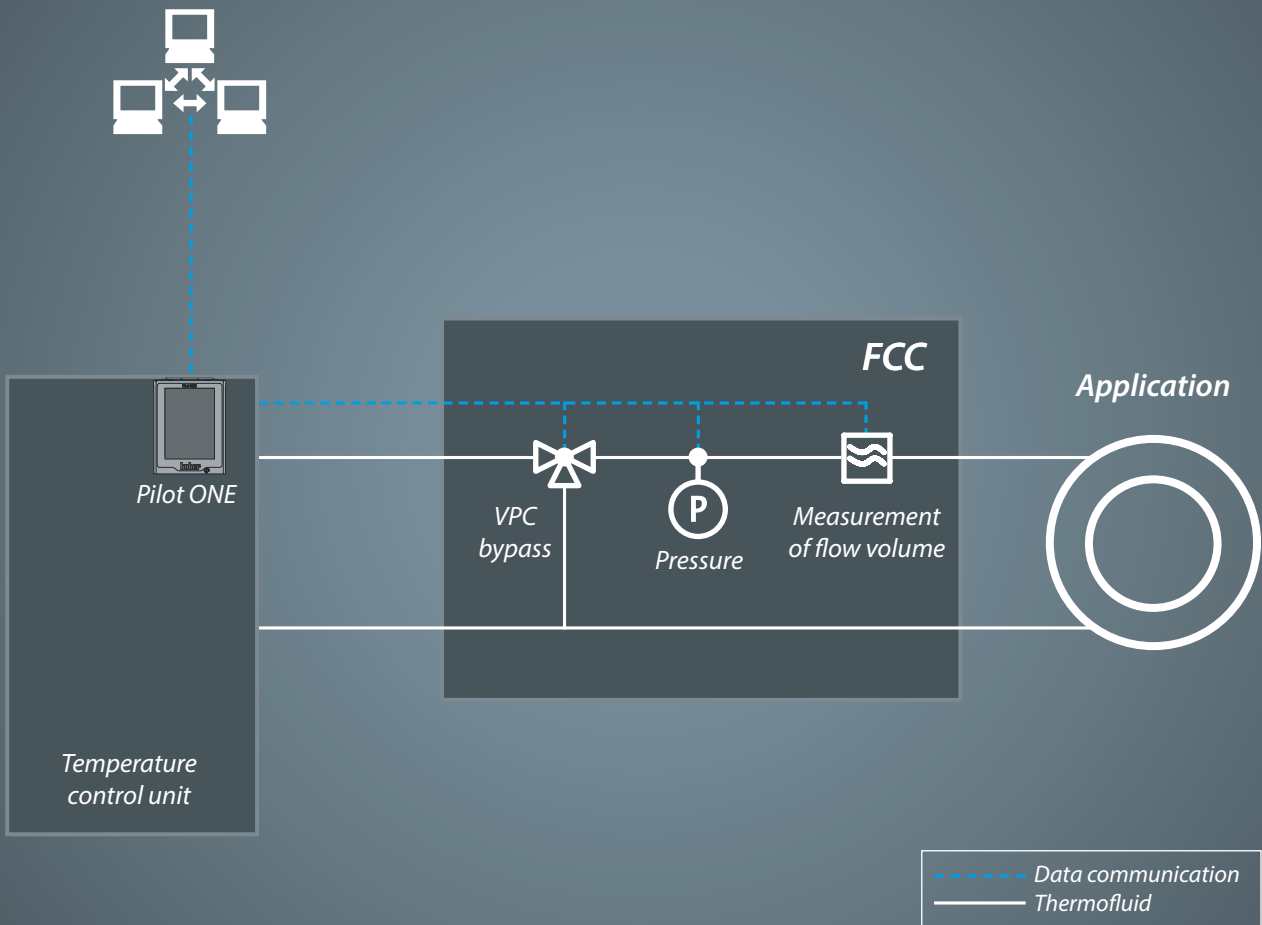

# Flow measurement and control

## Multi Flow Control Cube

The Multi Flow Control Cubes are used to measure and control the flow and pressure of the thermal fluid. In contrast to FCC, M-FCC has an independent controller, i.e. control takes place autonomously and communication with the Pilot ONE of the temperature control unit is not necessary. With M-FCC, multi-circuit control can be realised.

In most applications, a single temperature control unit is connected to an FCC for the first control loop. Additional M-FCC products are added for all further control loops.

For more flexibility and redundancy, we recommend a redundant temperature control unit as a backup for multiple control loops. Our field service will be happy to advise you on this topic.

- M-FCC MID is suitable for electrically conductive liquids (e.g. water or water-glycol mixtures)
- M-FCC TURB is suitable for all Huber fluids (e.g. DWTherm or silicone oils such as M60.115/200.06)
- The turbine can be calibrated for different tempering fluids (e.g. for Huber fluids or also water-glycol mixtures)

	<b>Multi Flow Control Cube MID<sup>1</sup></b> ▶ Flow measurement magnetically-inductive	<b>Multi Flow Control Cube TURB</b> ▶ Flow measurement via turbine
Temperature range	-40 ... 130 °C	-90 ... 250 °C
Permitted fluids	Water or Water/Glycol	Water/Glycol 50/50 <sup>2</sup>
Accuracy flow control <sup>3</sup>	up to ± 0,1 l/min	up to ± 0,2 l/min
Min. volume flow	0,2 l/min	0,9 l/min
Max. volume flow	80 l/min	95 l/min
Max. permitted pressure	6,0 bar	6,0 bar
Dimensions WxDxH	420x593x591 mm	420x593x591 mm
Weight, netto	approx. 51 kg	approx. 51 kg
Noise level	approx. 43 dB (A)	approx. 43 dB (A)
Fluid connection	M30x1,5 AG	M30x1,5 AG
Power supply	90–240V 1~/2~ 50/60Hz	90–240V 1~/2~ 50/60Hz
Max. current	0,2 A	0,2 A
Fuse protection	2,0 A	2,0 A
Protection class	IP20	IP20
Min. ambient temperature	5 °C	5 °C
Max. ambient temperature	40 °C	40 °C
Suitable for units	Applications with volume flow of max. 85 l/min	Applications with volume flow of max. 95 l/min <sup>4</sup>
Construction / Design	On castors, loose <sup>5</sup>	On castors, loose <sup>5</sup>
Internal Com.G@te	Optional #31217	Optional #31217
<b>Cat.No.</b>	<b>3601.0001.01</b>	<b>3601.0002.01</b>

<sup>1</sup> Due to the technology used, the MID does not have to be explicitly matched to the medium used

<sup>2</sup> Calibration factory set up with 50/50, adjustment to another medium can be done by customer

<sup>3</sup> At 20 °C and water-glycol mixture 50/50. The accuracy is influenced by various factors (in particular the set flow rate, the fluid used, the fluid temperature).

<sup>4</sup> Volume flow >95 l/min on request

<sup>5</sup> Accessories for use with the FCC e.g. hoses, adapters, etc. must be ordered separately



Interface options:  
 RS232/485, USB, Ethernet,  
 Modbus TCP, Profibus, OPC-UA

### MULTI-CIRCUIT CONTROL WITH MULTIPLE M-FCC

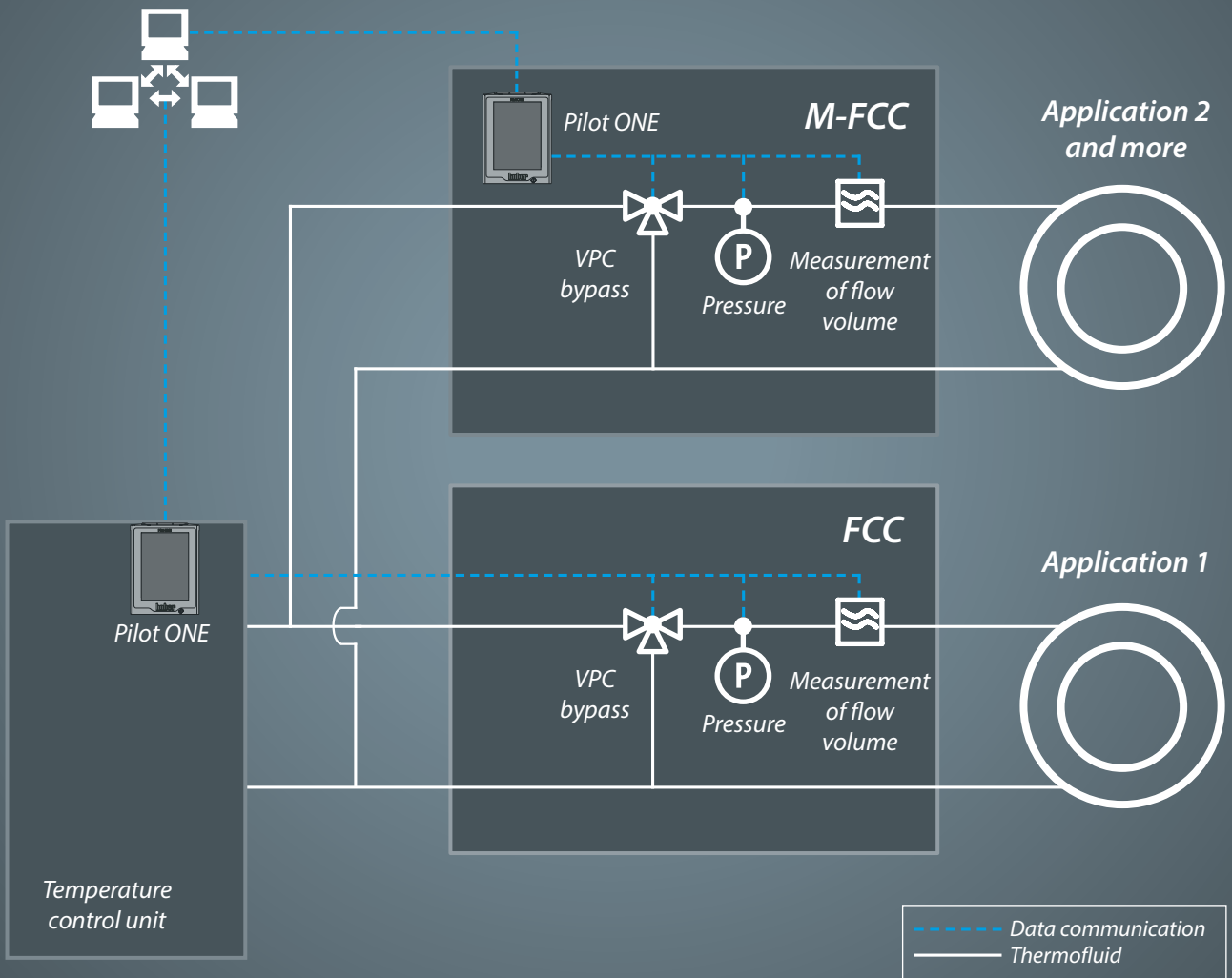

# Interfaces PROFINET gateway



PROFINET (Process Field Network) is the open Industrial Ethernet standard of the PROFIBUS user organisation e. V. (PNO) based on Ethernet-TCP/IP and complements Profibus technology for applications that require fast data communication via Ethernet networks in combination with industrial IT functions. PROFINET can be used to implement solutions for manufacturing technology, process automation, building automation and the entire spectrum of drive technology. With the PROFINET gateway, Huber temperature control units can be integrated into PROFINET networks easily, flexibly and close to the process. The PROFINET gateway is integrated into the project planning software with the aid of the associated GSDML file.

*PROFINET-side*

*Ethernet-side*

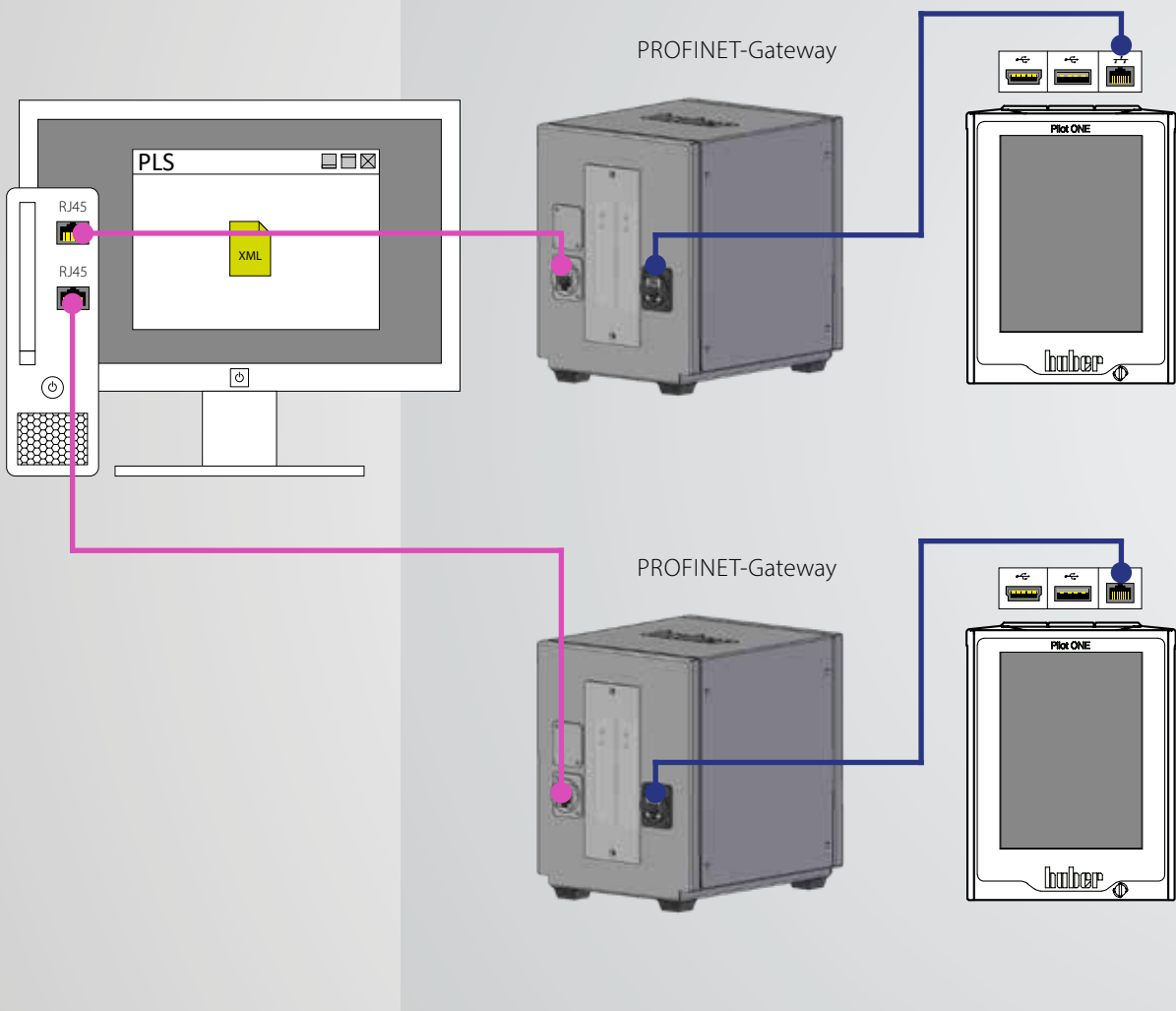

Model	Cat.No.
PROFINET-Gateway	10965

# Interfaces EtherCAT gateway



EtherCAT, short for Ethernet for Control Automation Technology, is an open Ethernet-based fieldbus technology that is standardised in international standards. EtherCAT is a very fast Industrial Ethernet system that is also suitable for use in time-critical applications. With the EtherCAT gateway, Huber temperature control units can be integrated into EtherCAT networks easily, flexibly and close to the process. The EtherCAT gateway is integrated into the configuration software with the aid of the associated GSDML file.

*EtherCAT-side*

*Ethernet-side*

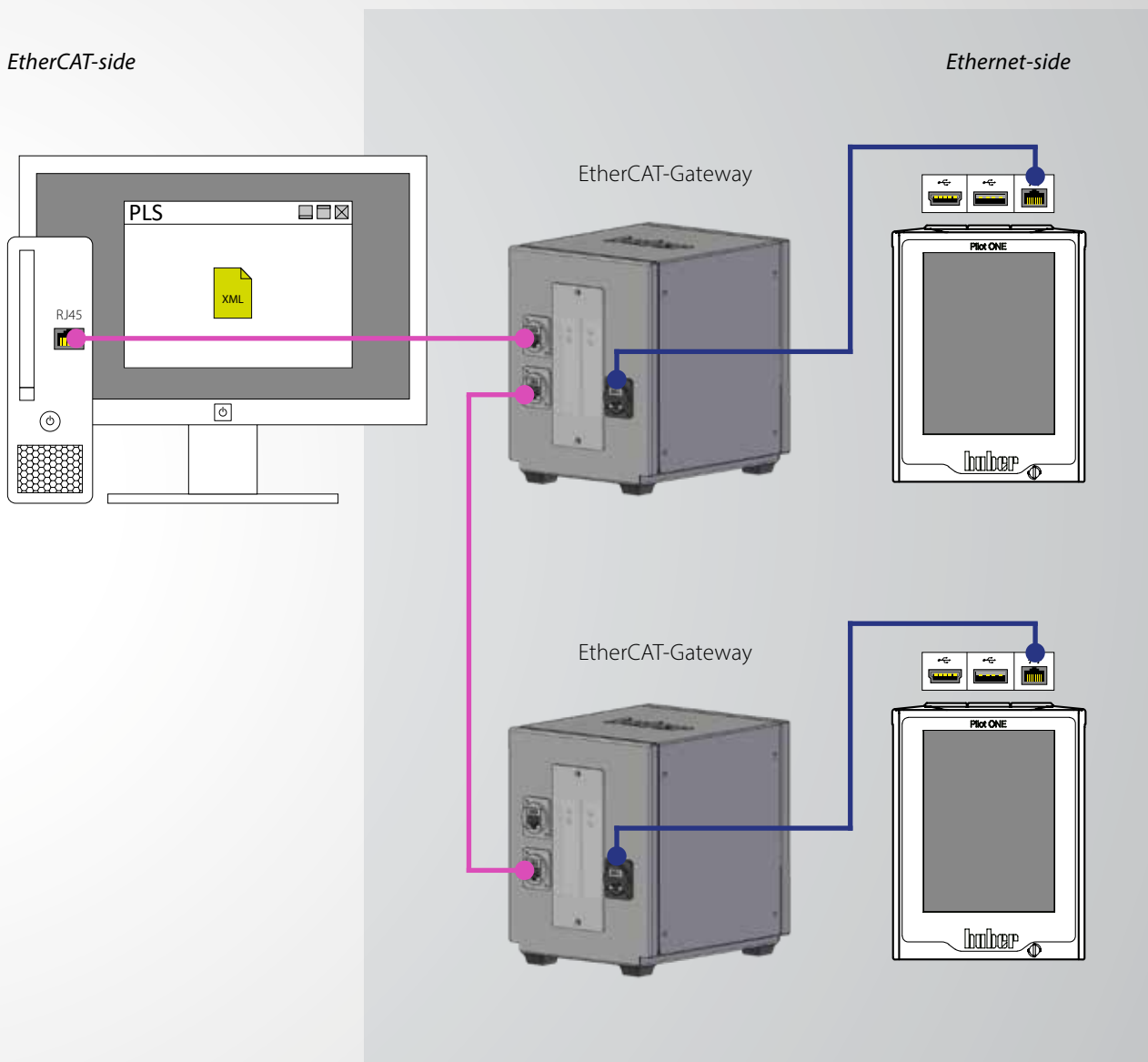

Model	Cat.No.
EtherCAT-Gateway	10966

# Special Solutions

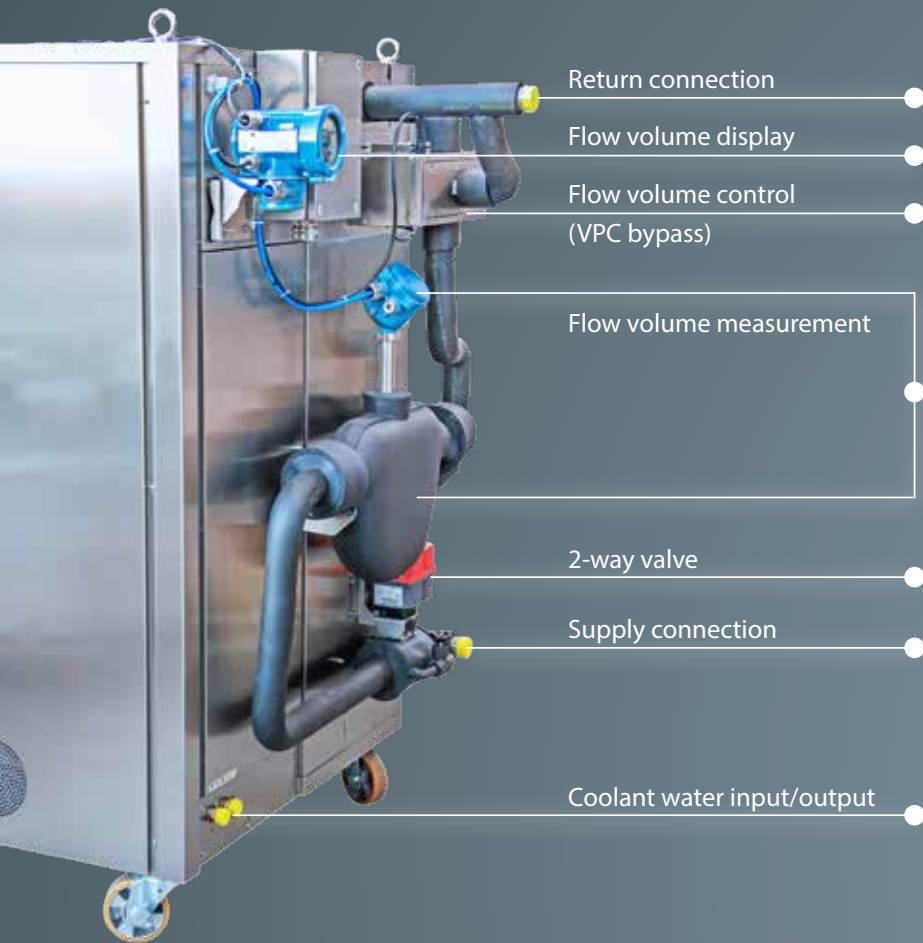

## ATTACHMENTS ON THE BACK

Optional components such as flow meter, bypass etc can be fitted at the customer site or integrated onto the unit during the construction.

Our Engineering team are experience and knowledgeable and would be delighted to discuss the best solution for your application.

## MODELS „ON TOP“

In these models, all additional components have been built "on top" of the temperature control unit. This kept the footprint and required space to a minimum.

Equipment built into the structural housing includes a bypass, volume flow meter, interfaces etc.



## DIRECT OPERATION OR WITH HEAT EXCHANGER

There are basically two operation versions available for the temperature control unit. Version 1 is operation via an external heat exchanger. The advantage is this: The application circuit and temperature control circuit are separated, and on the application side, any temperature control liquid can be used. Version 2 is direct operation e.g. with water glycol, 3M Novec or other permissible temperature control media.

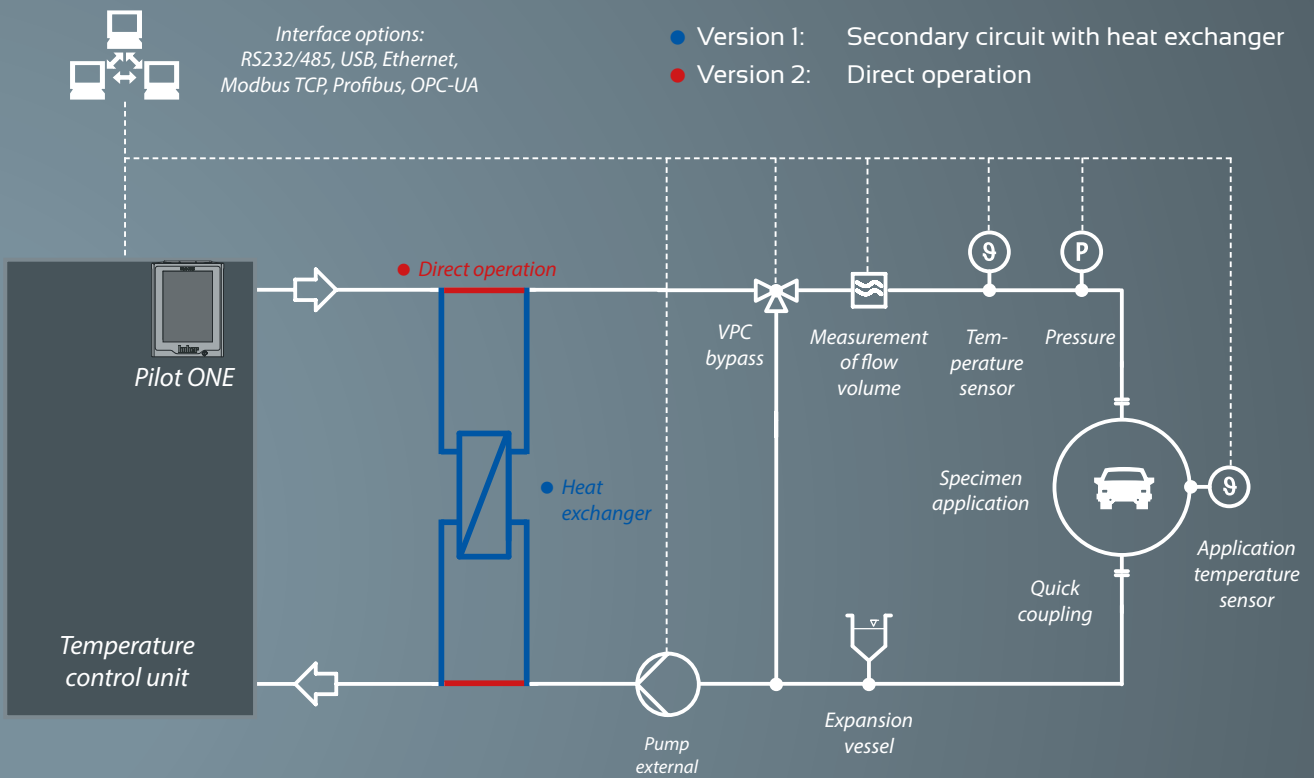

## HEAT EXCHANGER

External heat exchanger for separation of fluid circuits of temperature control unit and application allow indirect operation with almost all temperature control liquids (e.g. in the event of viscosity problems, material incompatibilities).



# Examples of use



## Fuel temperature control

Huber temperature control equipment is used for cyclical heating/cooling of petrol or diesel. Dynamic temperature control systems are particularly suitable for this test, as they can change temperature quickly and cover a wide temperature range.



## Cold filter plugging point

The most important test for the cold temperature resistance of the diesel fuel is the filter performance defined by the CFPP or Cold Filter Plugging Point Test in accordance with EN 116. At temperatures below the freezing point, paraffin crystals can increase the flow resistance in the fuel filter, reducing or stopping the flow of fuel.



## Material deformation

Components such as condensers, air lines and exhausts are frequently exposed to temperature fluctuations from -90 °C to +150 °C. The behaviour of the materials in the different components can be tested with cold bath circulation thermostats under a range of load conditions.



## AdBlue® temperature control

This application takes place in the SCR (selective catalytic reduction) catalytic converter. Using selective catalytic reduction, the emission of nitrogen oxide (NOx) is reduced by around 90% (in stationary operation). The liquid is a clear, synthesised 32.5 percent solution of high-purity urea in demineralised water.





## Exhaust test

We supply a range of different temperature control units for fogging tests (in accordance with EN 14288 and DIN 75201) for individual components in car interiors.

When they warm up, the volatile constituents escape from the component and condense in the (colder) environment.

The KISS and CC series are used to heat the sample while the (e.g.) Minichiller is used to condense the vapours for analysis.



## Transmission oil test

For transmission oil tests, you can use a Unistat with operational temperatures from  $-40\text{ }^{\circ}\text{C}$  to  $+250\text{ }^{\circ}\text{C}$  for temperature control. The transmission oil is pumped through a plate heat exchanger and flows through defined temperature profiles in various cycles.



## Softening point

The Vicat Test is used to make statements about the softening point of plastics. A rounded needle with a flat end is pressed onto the sample with a defined pressure and continuous increase in ambient temperature. Depending on the test conditions chosen, the constant temperature increase must be  $50\text{ }^{\circ}\text{C}$  or  $120\text{ }^{\circ}\text{C}$  per hour, until the softening temperature (VST) is reached, and the needle can penetrate 1 mm into the material.

# Examples of use



## Optics, telescopes

Unistats are used for high-precision temperature control of calibration and vacuum chambers, in order to test and calibrate optical telescopes for space research. The parts and functional components are subjected to real conditions using high vacuum systems.



## Additives, lubricants

Temperature-dependent test processes for development, optimisation and quality assurance of additives and lubricants. Typical objectives include improving the cold temperature behaviour of viscosity as well as optimisation of resistance to ageing, corrosion protection, dispersing capacity and foaming behaviour.



## Pump test

Temperature control for pump test units for pumps for liquid and gaseous media. Exact temperature control delivers a high level of measurement accuracy and reproducibility for all parameters. Typical tests where the influence of temperature plays a major role include pressure tests, flow volume measurements, noise measurements, power consumption, leak tests and long-term durability tests.



## Sensors

Unistats combined with the Unical calibration bath are ideal for functional testing and calibration of sensors such as Pt100 sensors. The stainless-steel bath is set up like a calorimeter, and so achieves excellent temperature homogeneity.

The individual temperature cycles can be prescribed using a programmer or control via a digital interface.



## Corrosion testing

Vehicle chassis components are exposed to temperature fluctuations, moisture and environmental influences every day. These environmental conditions are recreated in special test chambers using mist, dry phases, salt solutions and other corrosive solutions.

The cyclical temperature fluctuations are critical here. Dynamic temperature units from Huber are ideal here, to test precise temperature changes over several test phases.



## Material stress test

In the automotive industry, all vehicle components must undergo a wide range of stress tests - often under extreme climatic conditions. The components must be able to withstand the stress of cyclical, changing temperatures for several weeks or months. Unistats are the perfect choice here. The units are designed for reliable, permanent operation, and facilitate extremely rapid temperature change.



## Battery test

One use of lithium ion batteries is in electric vehicles. These must pass a range of temperature tests before installation. For this, an ambient temperature from  $-20^{\circ}\text{C}$  to  $+40^{\circ}\text{C}$  is created in an environmental chamber. A Unistat, which can control temperature from  $-40^{\circ}\text{C}$  to  $+100^{\circ}\text{C}$ , is connected at a test point inside the environmental chamber using hoses.



## Special solutions

If you need a temperature control solution specially adapted to your requirements, then we look forward to your enquiry. We would be delighted to offer personalised advice and give you suitable approaches to a solution, or show you reference projects we have already completed with comparable requirements.

# Inspired by **temperature** designed for you



**Алматы** (7273)495-231  
**Ангарск** (3955)60-70-56  
**Архангельск** (8182)63-90-72  
**Астрахань** (8512)99-46-04  
**Барнаул** (3852)73-04-60  
**Белгород** (4722)40-23-64  
**Благовещенск** (4162)22-76-07  
**Брянск** (4832)59-03-52  
**Владивосток** (423)249-28-31  
**Владикавказ** (8672)28-90-48  
**Владимир** (4922)49-43-18  
**Волгоград** (844)278-03-48  
**Вологда** (8172)26-41-59  
**Воронеж** (473)204-51-73  
**Екатеринбург** (343)384-55-89

**Ижевск** (3412)26-03-58  
**Иваново** (4932)77-34-06  
**Иркутск** (395)279-98-46  
**Казань** (843)206-01-48  
**Калининград** (4012)72-03-81  
**Калуга** (4842)92-23-67  
**Кемерово** (3842)65-04-62  
**Киров** (8332)68-02-04  
**Коломна** (4966)23-41-49  
**Кострома** (4942)77-07-48  
**Краснодар** (861)203-40-90  
**Красноярск** (391)204-63-61  
**Курск** (4712)77-13-04  
**Курган** (3522)50-90-47  
**Липецк** (4742)52-20-81

**Киргизия** (996)312-96-26-47

**Магнитогорск** (3519)55-03-13  
**Москва** (495)268-04-70  
**Мурманск** (8152)59-64-93  
**Набережные Челны** (8552)20-53-41  
**Нижний Новгород** (831)429-08-12  
**Новокузнецк** (3843)20-46-81  
**Новыйорск** (3496)41-32-12  
**Новосибирск** (383)227-86-73  
**Омск** (3812)21-46-40  
**Орел** (4862)44-53-42  
**Оренбург** (3532)37-68-04  
**Пенза** (8412)22-31-16  
**Петрозаводск** (8142)55-98-37  
**Пермь** (8112)59-10-37  
**Псков** (342)205-81-47

**Россия** (495)268-04-70

**Ростов-на-Дону** (863)308-18-15  
**Рязань** (4912)46-61-64  
**Самара** (846)206-03-16  
**Саранск** (8342)22-96-24  
**Санкт-Петербург** (812)309-46-40  
**Саратов** (845)249-38-78  
**Севастополь** (8692)22-31-93  
**Симферополь** (3652)67-13-56  
**Смоленск** (4812)29-41-54  
**Сочи** (862)225-72-31  
**Ставрополь** (8652)20-65-13  
**Сыктывкар** (8212)25-95-17  
**Сургут** (3462)77-98-35  
**Тамбов** (4752)50-40-97  
**Тверь** (4822)63-31-35

**Казахстан** (772)734-952-31

**Тольяти** (8482)63-91-07  
**Томск** (3822)98-41-53  
**Тула** (4872)33-79-87  
**Тюмень** (3452)66-21-18  
**Улан-Удэ** (3012)59-97-51  
**Ульяновск** (8422)24-23-59  
**Уфа** (347)229-48-12  
**Хабаровск** (4212)92-98-04  
**Чебоксары** (8352)28-53-07  
**Челябинск** (351)202-03-61  
**Череповец** (8202)49-02-64  
**Чита** (3022)38-34-83  
**Якутск** (4112)23-90-97  
**Ярославль** (4852)69-52-93

<https://huber.nt-rt.ru> || [hru@nt-rt.ru](mailto:hru@nt-rt.ru)